

PLAYING A SONG

Ukulele Tuesdays – Evergreen Library
February 26, 2019

1



2

PLAYING MUSIC IS MORE THAN JUST MEMORIZING A BUNCH OF CHORDS ON YOUR INSTRUMENT.

That's difficult. And takes a long time.

MAIN ELEMENTS SONG

- **Introduction (or Intro)** – The introduction is a unique section that comes at the beginning of the piece. Generally speaking, an introduction contains just music and no words. It usually builds up suspense for the listener so when the downbeat drops in, it creates a pleasing sense of release. The intro also creates the atmosphere of the song.
- **Verse** – A verse roughly corresponds to a poetic stanza because it consists of rhyming lyrics most often with an AABB or ABAB rhyme scheme. When two or more sections of the song have almost identical music but different lyrics, each section is considered one verse. They contain the “story” of the song.
- **Chorus / Refrain** – This is the phrase that repeats periodically throughout the song. The chorus contains the main idea, or big picture, of what is being expressed lyrically and musically. Usually resolves to the root note of the song’s key.

OTHER ELEMENTS

- **Pre-Chorus** – This is a short interlude of a phrase or two that is in a different key than the usual key of the song. It gives a bit of interest to the flow of the song, breaking. Also known as a "build", "channel", or "transitional bridge", the pre-chorus functions to connect the verse to the chorus with intermediary material, typically using subdominant or similar transitional harmonies
- **Bridge** – The bridge is a device that is used to break up the repetitive pattern of the song and keep the listener's attention. In a bridge, the pattern of the words and music change. This is a short interlude of a phrase or two that is in a different key than the usual key of the song. It gives a bit of interest to the flow of the song, breaking up the Verse – Chorus sequence.
- **Instrumental / Solo / Break** – This can be any type of short instrumental or solo within a song. It could be a verse or chorus or something else, even a bridge. It could be played by one instrumentalist (solo) or multiple instrumentalists.
- **Conclusion (or Outro)** – The conclusion or outro of a song is a way of ending or completing the song. It signals to the listeners that the song is nearing its close. The reason for having an outro is that if a song just ended at the last bar of a section, such as on the last verse or the last chorus, this might feel too abrupt for listeners. Usually a repeat of the final line of the Chorus.

SONG STRUCTURES

- There are many, MANY ways to structure a song.
- There are no rules for how to structure it.
- There are some common sequences, however.

Verse, then Chorus

Verse 1	<u>Examples</u>
Chorus	Will the Circle be Unbroken
Verse 2	You are my Sunshine
Chorus	This Land is Your Land
Verse 3	American Pie
Chorus	Hallelujah
...	

Verses Only

Verse 1	<u>Examples</u>
Verse 2	Kookaburra (in the Old Gum Tree)
Verse 3	Folsom Prison Blues
Verse 4	A Boy Named Sue
....	Where Have All the Flowers Gone

SONG STRUCTURES

2 Verses, then Chorus

Verse 1 **Examples**
Verse 2 A Horse with No Name
Chorus
Verse 3
Verse 4
Chorus
....

Verses, Chorus and Bridge

Verse 1 **Examples**
Chorus Country Roads
Verse 2
Chorus
Bridge
Chorus

Only 1 Verse in the song

Verse 1 **Examples**
Chorus Kookaburra (in the Old Gum Tree)
Chorus Folsom Prison Blues
Chorus A Boy Named Sue
Verse 1
Chorus
....

EXAMPLES

- **Day-O (The Banana Boat Song)** by Harry Belafonte

- [https://www.internetchorddatabase.com/Songs/Day-O \(The Banana Boat Song\) by Harry Belafonte](https://www.internetchorddatabase.com/Songs/Day-O_(The_Banana_Boat_Song)_by_Harry_Belafonte)

Intro
Verse 1
Bridge
Verse 2
Chorus
Verse 3
Verse 2
Chorus
Bridge
Outro

- **Ring of Fire** by Johnny Cash

- [https://www.internetchorddatabase.com/Songs/Ring of Fire by Johnny Cash](https://www.internetchorddatabase.com/Songs/Ring_of_Fire_by_Johnny_Cash)

Intro
Verse 1
Chorus
Break
Chorus
Verse 2
Chorus
Chorus

- **Country Roads** by John Denver

- [https://www.internetchorddatabase.com/Songs/Country Roads by John Denver](https://www.internetchorddatabase.com/Songs/Country_Roads_by_John_Denver)

Verse 1
Chorus
Verse 2
Chorus
Break
Outro / Chorus

DAY-O (THE BANANA BOAT SONG)

Intro (lead only)

Daaay-o, Day-ay-ay- o.

Daylight come an' me wan' go home.

Day, me say day, me say day, me say day, me sa day, me say daay-o

Daylight come an' me wan' go home.

Verse 1

(lead) Work all night on a drink a' rum

(response) Daylight come an' me wan' go home.

(lead) Stack banana till de mornin' come

(response) Daylight come an' me wan' go home.

Bridge

(lead) Come, Mister tally man tally me banana.

(response) Daylight come an' me wan' go home.

(lead) Come, Mister tally man tally me banana.

(response) Daylight come an' me wan' go home.

Verse 2

(lead) Lift Six foot, seven foot, eight foot bunch

(response) Daylight come an' me wan' go home.

(lead) Six foot, seven foot, eight foot bunch

(response) Daylight come an' me wan' go home.

.....

.....

Chorus

(lead) Day, me say Day-ay-ay- o.

(response) Daylight come an' me wan' go home.

(lead) Day, me say day, me say day, me say day, me sa day, me say...

(response) Daylight come an' me wan' go home.

Verse 3

(lead) Beautiful bunch of ripe banana

(response) Daylight come an' me wan' go home.

(lead) Hide the deadly, black taranch-la

(response) Daylight come an' me wan' go home.

REPEAT VERSE 2

REPEAT CHORUS

REPEAT BRIDGE

Outro

(lead) Daaay-o, Day-ay-ay- o.

(response) Daylight come an' me wan' go home.

(lead) Day, me say day, me say day, me say day, me sa day, me say daay-o

(response) Daylight come an' me wan' go home.

INTRO LINE — PICKING THE MELODY

C G7 F C G7 C
C B A G F E-D-C

Day, me sa' day, me sa' day, me sa' day, me sa' day, me say daay-o

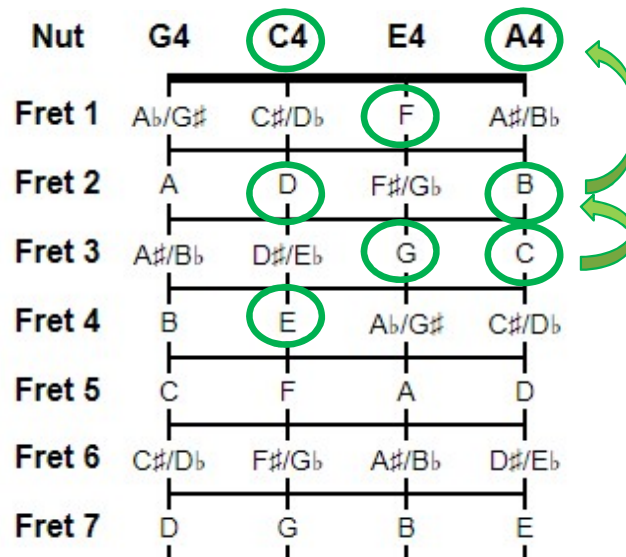

(pull off the D to C)



QUESTIONS?